

Teori Pengambilan Keputusan

Week 6 – Transportation Models

Bachelor of Business Administration
Communication and Business School
Telkom University



Outline

- ✓ Transportation Modeling
- ✓ Developing an Initial Solution
 - ✓ The Northwest-Corner Rule
 - ✓ The Intuitive Lowest-Cost Method
 - ✓ Vogel's Approximation Method
- ✓ Optimization method
 - ✓ The Stepping-Stone Method
 - ✓ MODI (Modified Distribution) Method
- ✓ Special Issues in Modeling
 - ✓ Demand Not Equal to Supply
 - ✓ Degeneracy

Learning Objectives

When you complete this module you should be able to:

1. Develop an initial solution to a transportation models with the northwest-corner, intuitive lowest-cost methods and Vogel's Approximation Method
2. Solve a problem with the stepping-stone and MODI (Modified Distribution method
3. Balance a transportation problem
4. Solve a problem with degeneracy

Transportation Modeling

- ☑ An interactive procedure that finds the least costly means of moving products from a series of sources to a series of destinations
- ☑ Can be used to help resolve distribution and location decisions



Transportation Modeling

- ☑ A special class of linear programming
- ☑ Need to know
 1. The origin points and the capacity or supply per period at each
 2. The destination points and the demand per period at each
 3. The cost of shipping one unit from each origin to each destination

Transportation Problem

<i>From</i>	<i>To</i>	<i>Albuquerque</i>	<i>Boston</i>	<i>Cleveland</i>
<i>Des Moines</i>		\$5	\$4	\$3
<i>Evansville</i>		\$8	\$4	\$3
<i>Fort Lauderdale</i>		\$9	\$7	\$5

Table C.1

Transportation Problem

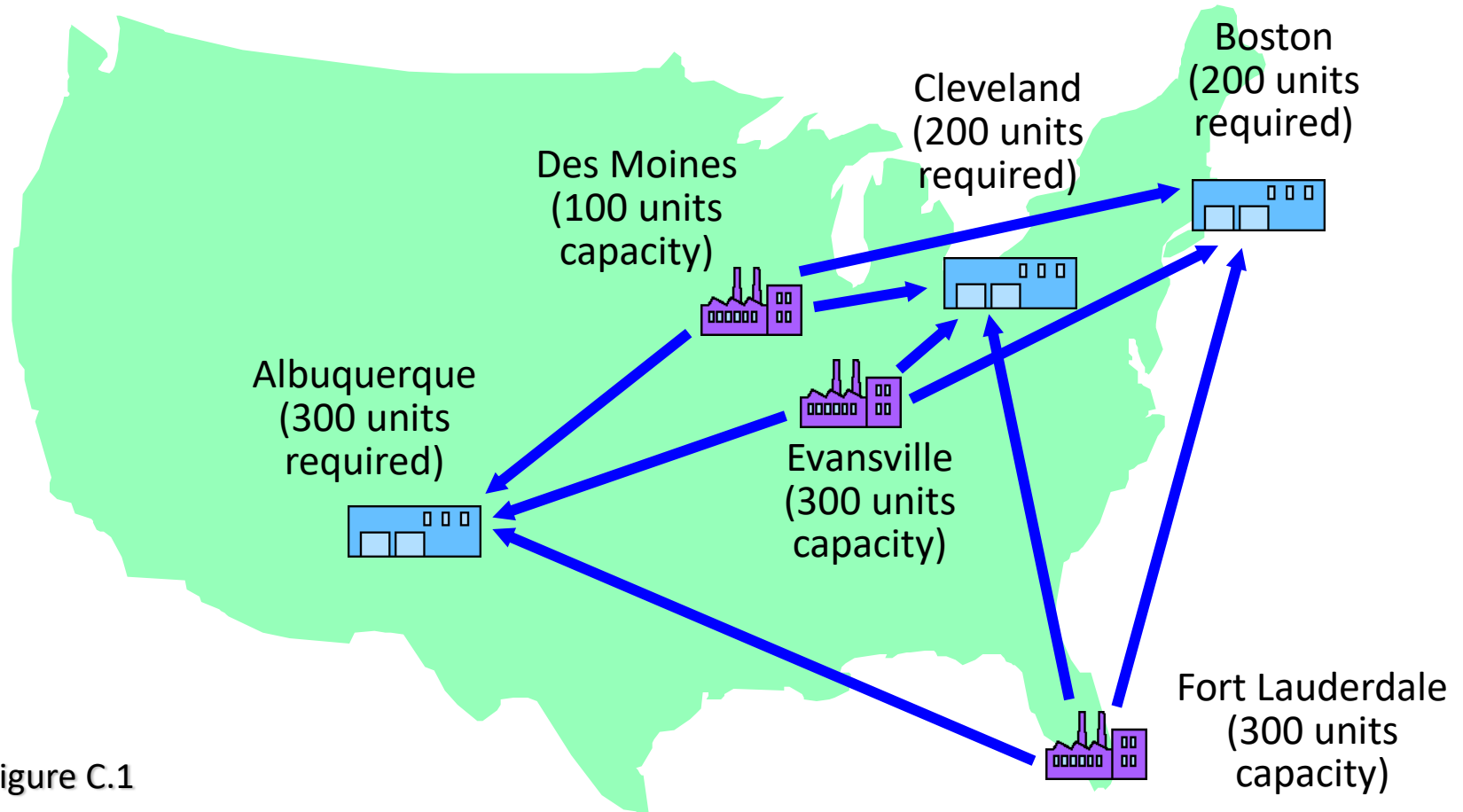

Figure C.1

Transportation Matrix

Table 9.2

From \ To	Albuquerque	Boston	Cleveland	Factory capacity
Des Moines	\$5	\$4	\$3	100
Evansville	\$8	\$4	\$3	300
Fort Lauderdale	\$9	\$7	\$5	300
Warehouse requirement	300	200	200	700

Des Moines capacity constraint

Cell representing a possible source-to-destination shipping assignment (Evansville to Cleveland)

Cost of shipping 1 unit from Fort Lauderdale factory to Boston warehouse

Cleveland warehouse demand

Total demand and total supply

OPTIMIZATION

Optimization

1. Start with initial solution.
 - Northwest Corner Rule
 - Intuitive Lowest-Cost Method
 - Vogel's Approximation Method
2. Continue with optimization method

Stepping-Stone Method

1. Select any unused square to evaluate
2. Beginning at this square, trace a closed path back to the original square via squares that are currently being used
3. Beginning with a plus (+) sign at the unused corner, place alternate minus and plus signs at each corner of the path just traced

Stepping-Stone Method

4. Calculate an improvement index by first adding the unit-cost figures found in each square containing a plus sign and subtracting the unit costs in each square containing a minus sign
5. Repeat steps 1 through 4 until you have calculated an improvement index for all unused squares. If all indices are ≥ 0 , you have reached an optimal solution.

Stepping-Stone Method

From \ To	(A) Albuquerque	(B) Boston	(C) Cleveland	Factory capacity
(D) Des Moines	100 $\$5$	$\$4$	$\$3$	100
(E) Evansville	200 $\$8$	$\$4$	$\$3$	300
(F) Fort Lauderdale	$\$9$	100 $\$7$	200 $\$5$	300
Warehouse requirement	300	200	200	700

Des Moines-Boston index
 $= \$4 - \$5 + \$8 - \4
 $= +\$3$

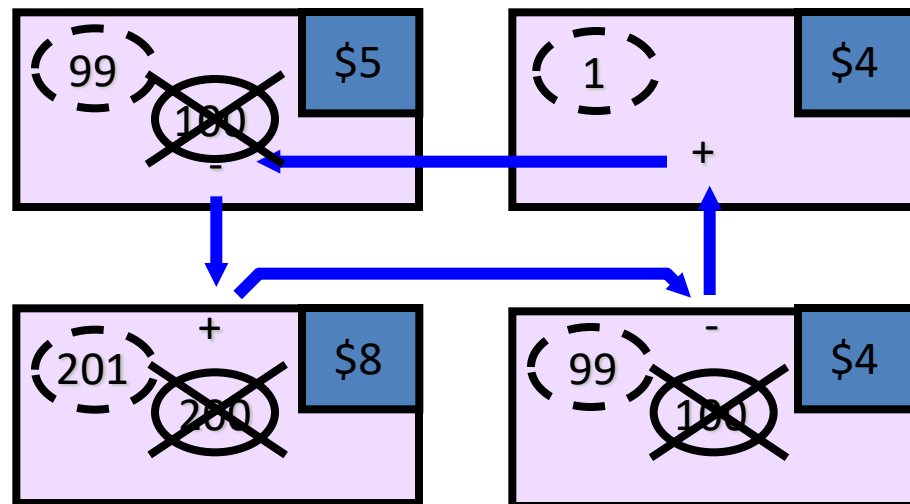

Table 9.4

Stepping-Stone Method

From \ To	(A) Albuquerque	(B) Boston	(C) Cleveland	Factory capacity
(D) Des Moines	100 -\$5	\$4	Start +\$3	100
(E) Evansville	200 +\$8	100 -\$4	\$3	300
(F) Fort Lauderdale	\$9	100 +\$7	200 -\$5	300
Warehouse requirement	300	200	200	700

Diagram illustrating the Stepping-Stone Method with flow adjustments (dashed blue arrows) and unit costs:

- Des Moines (D) to Albuquerque (A): -100 units, cost \$5
- Des Moines (D) to Cleveland (C): +100 units, cost \$3
- Evansville (E) to Albuquerque (A): +200 units, cost \$8
- Evansville (E) to Boston (B): -100 units, cost \$4
- Fort Lauderdale (F) to Boston (B): +100 units, cost \$7
- Fort Lauderdale (F) to Cleveland (C): -200 units, cost \$5

Des Moines-Cleveland index

$$= \$3 - \$5 + \$8 - \$4 + \$7 - \$5 = +\$4$$

Table 9.5

Stepping-Stone Method

From \ To	(A) Albuquerque	(B) Boston	(C) Cleveland	Factory capacity
(D) Des Moines	100 \$5	\$4	\$3	100
(E) Evansville				
(F) Fort Lauderdale				
Warehouse requirement				

Evansville-Cleveland index

$$= \$3 - \$4 + \$7 - \$5 = +\$1$$

(Closed path = EC - EB + FB - FC)

Fort Lauderdale-Albuquerque index

$$= \$9 - \$7 + \$4 - \$8 = -\$1$$

(Closed path = FA - FB + EB - EA)

Stepping-Stone Method

1. If an improvement is possible, choose the route (unused square) with the largest negative improvement index
2. On the closed path for that route, select the smallest number found in the squares containing minus signs
3. Add this number to all squares on the closed path with plus signs and subtract it from all squares with a minus sign

Stepping-Stone Method

From \ To	(A) Albuquerque	(B) Boston	(C) Cleveland	Factory capacity
(D) Des Moines	100 \$5	\$4	\$3	100
(E) Evansville	200 \$8	100 \$4	\$3	300
(F) Fort Lauderdale	\$9	100 \$7	200 \$5	300
Warehouse requirement				

Diagram illustrating the Stepping-Stone Method adjustments:

- Blue dashed arrows show a cycle: +100 units on route FA, -100 units on route FB, +100 units on route EB, and -100 units on route EA.
- The cell for route FA (Fort Lauderdale to Albuquerque) is highlighted in yellow.

1. Add 100 units on route FA
2. Subtract 100 from routes FB
3. Add 100 to route EB
4. Subtract 100 from route EA

Table 9.6

Stepping-Stone Method

From \ To	(A) Albuquerque	(B) Boston	(C) Cleveland	Factory capacity
(D) Des Moines	100 \$5	\$4	\$3	100
(E) Evansville	100 \$8	200 \$4	\$3	300
(F) Fort Lauderdale	100 \$9	\$7	200 \$5	300
Warehouse requirement	300	200	200	700

$$\begin{aligned}
 \text{Total Cost} &= \$5(100) + \$8(100) + \$4(200) + \$9(100) + \$5(200) \\
 &= \$4,000
 \end{aligned}$$

Table 9.7

Stepping-Stone Method

From \ To	(A) Albuquerque	(B) Boston	(C) Cleveland	Factory capacity
(D) Des Moines	100 \$5	\$4	\$3	100
(E) Evansville	\$8	\$4	\$3	
(F) Fort Lauderdale				
Warehouse requirement				

Des Moines-Boston index

$$= \$4 - \$5 + \$8 - \$4 = +\$3$$

(Closed path = DB - DA + EA - EB)

Des Moines-Cleveland index

$$= \$3 - \$5 + \$9 - \$5 = +\$2$$

(Closed path = DC - DA + FA - FC)

Stepping-Stone Method

From \ To	(A) Albuquerque	(B) Boston	(C) Cleveland	Factory capacity
(D) Des Moines	100 \$5	\$4	\$3	100
(E) Evansville	\$8	\$4	\$3	
(F) Fort Lauderdale				
Warehouse requirement				

Evansville-Cleveland index

$$= \$3 - \$8 + \$9 - \$5 = -\$1$$

(Closed path = EC - EA + FA - FC)

Fort Lauderdale-Boston index

$$= \$7 - \$4 + \$8 - \$9 = +\$2$$

(Closed path = FB - EB + EA - FA)

Stepping-Stone Method

From \ To	(A) Albuquerque	(B) Boston	(C) Cleveland	Factory capacity
(D) Des Moines	100 \$5	\$4	\$3	100
(E) Evansville	100 \$8	200 \$4	\$3	300
(F) Fort Lauderdale	100 \$9	\$7	200 \$5	300
Warehouse requirement	300	200	200	700

Diagram illustrating the Stepping-Stone Method adjustments:

- A dashed blue arrow points from the (E) Evansville, (B) Boston cell (200) to the (E) Evansville, (A) Albuquerque cell (100), with a '-' sign at the destination and a '+' sign at the source.
- A dashed blue arrow points from the (E) Evansville, (A) Albuquerque cell (100) to the (F) Fort Lauderdale, (A) Albuquerque cell (100), with a '+' sign at the destination and a '-' sign at the source.
- A dashed blue arrow points from the (F) Fort Lauderdale, (A) Albuquerque cell (100) to the (F) Fort Lauderdale, (C) Cleveland cell (200), with a '-' sign at the destination and a '+' sign at the source.

Table 9.8

Stepping-Stone Method

From \ To	(A) Albuquerque	(B) Boston	(C) Cleveland	Factory capacity
(D) Des Moines	100 \$5	\$4	\$3	100
(E) Evansville	\$8	200 \$4	100 \$3	300
(F) Fort Lauderdale	200 \$9	\$7	100 \$5	300
Warehouse requirement	300	200	200	700

$$\begin{aligned}
 \text{Total Cost} &= \$5(100) + \$4(200) + \$3(100) + \$9(200) + \$5(100) \\
 &= \$3,900
 \end{aligned}$$

Table 9.9

Special Issues in Modeling

- ☑ Demand not equal to supply
 - ☑ Called an unbalanced problem
 - ☑ Common situation in the real world
 - ☑ Resolved by introducing dummy sources or dummy destinations as necessary with cost coefficients of zero

$$\text{Total Cost} = 250(\$5) + 50(\$8) + 200(\$4) + 50(\$3) + 150(\$5) + 150(0)$$

$$= \$3,350$$

From \ To	(A) Albuquerque	(B) Boston	(C) Cleveland	Dummy	Factory capacity
(D) Des Moines	250 \$5	\$4	\$3	0	250
(E) Evansville	50 \$8	200 \$4	50 \$3	0	300
(F) Fort Lauderdale	\$9	\$7	150 \$5	150 0	300
Warehouse requirement	300	200	200	150	850

Figure C.9

New
Des Moines
capacity

Special Issues in Modeling

Degeneracy

- To use the stepping-stone methodology, the number of occupied squares in any solution must be equal to the number of rows in the table plus the number of columns minus 1
- If a solution does not satisfy this rule it is called degenerate

Special Issues in Modeling

From \ To	Customer 1	Customer 2	Customer 3	Warehouse supply
Warehouse 1	100 \$8	\$2	\$6	100
Warehouse 2	0 \$10	100 \$9	20 \$9	120
Warehouse 3	\$7	\$10	80 \$7	80
Customer demand	100	100	100	300

Initial solution is degenerate

Place a zero quantity in an unused square and proceed computing improvement indices

Figure C.10

MODI (Modified Distribution) Method

1. To compute the values for each row and column, set $R_i + K_j = C_{ij}$, but only for those squares that are currently used or occupied.
2. After all equations have been written, set $R_1 = 0$.
3. Solve the system of equations for all R and K values.
4. Compute the improvement index for each unused square by the formula improvement index $(I_{ij}) = C_{ij} - R_i - K_j$
5. Select the largest negative index and proceed to solve the problem as you did using the stepping-stone method.

MODI (Modified Distribution) Method

		K ₁		K ₂		K ₃		
		(A) Albuquerque		(B) Boston		(C) Cleveland		Factory capacity
From \ To								
R ₁	(D) Des Moines	100	\$5		\$4		\$3	100
R ₂	(E) Evansville	200	\$8	100	\$4		\$3	300
R ₃	(F) Fort Lauderdale		\$9	100	\$7	200	\$5	300
Warehouse requirement		300		200		200		700

MODI (Modified Distribution) Method

1. $R1 + K1 = 5$

2. $R2 + K1 = 8$

3. $R2 + K2 = 4$

4. $R3 + K2 = 7$

5. $R3 + K3 = 5$

MODI (Modified Distribution) Method

Letting $R_1 = 0$, we can easily solve, step by step, for K_1 , R_2 , K_2 , R_3 , and K_3 .

$$1. R_1 + K_1 = 5 \rightarrow 0 + K_1 = 5 \rightarrow K_1 = 5$$

$$2. R_2 + K_1 = 8 \rightarrow R_2 + 5 = 8 \rightarrow R_2 = 3$$

$$3. R_2 + K_2 = 4 \rightarrow 3 + K_2 = 4 \rightarrow K_2 = 1$$

$$4. R_3 + K_2 = 7 \rightarrow R_3 + 1 = 7 \rightarrow R_3 = 6$$

$$5. R_3 + K_3 = 5 \rightarrow 6 + K_3 = 5 \rightarrow K_3 = 1$$

MODI (Modified Distribution) Method

Des Moines–Boston index (I_{12}) =

$$C_{12} - R_1 - K_2 = +3$$

Des Moines–Cleveland index (I_{13}) =

$$C_{13} - R_1 - K_3 = +4$$

Evansville–Cleveland index (I_{23}) =

$$C_{23} - R_2 - K_3 = +1$$

Fort Lauderdale–Albuquerque index (I_{31}) =

$$C_{31} - R_3 - K_1 = -2$$

MODI (Modified Distribution) Method

		K ₁		K ₂		K ₃		
		(A) Albuquerque		(B) Boston		(C) Cleveland		Factory capacity
From	To							
R ₁	(D) Des Moines	100	\$5		\$4		\$3	100
R ₂	(E) Evansville	200	\$8	100	\$4		\$3	300
R ₃	(F) Fort Lauderdale		\$9	100	\$7	200	\$5	300
Warehouse requirement		300		200		200		700

A red dashed loop is drawn around the cells (E) Evansville to (B) Boston, (B) Boston to (F) Fort Lauderdale, and (F) Fort Lauderdale to (A) Albuquerque. The cell (F) Fort Lauderdale is labeled with C₃₁ in red.

Find the loop, and move as much as the smallest number in closest cell of the loop. In this case move 100 units

MODI (Modified Distribution) Method

Therefore the table would look like this:

From \ To	(A) Albuquerque	(B) Boston	(C) Cleveland	Factory capacity
(D) Des Moines	100 \$5	\$4	\$3	100
(E) Evansville	100 \$8	200 \$4	\$3	300
(F) Fort Lauderdale	100 \$9	\$7	200 \$5	300
Warehouse requirement	300	200	200	700

MODI (Modified Distribution) Method

- Following this procedure, the second solutions can be found in the next page.
- With each new MODI solution, we must recalculate the R and K values.
- These values then are used to compute new improvement indices in order to determine whether further shipping cost reduction is possible.

MODI (Modified Distribution) Method

From \ To	(A) Albuquerque	(B) Boston	(C) Cleveland	Factory capacity
(D) Des Moines	100 \$5	\$4	\$3	100
(E) Evansville	\$8	200 \$4	100 \$3	300
(F) Fort Lauderdale	200 \$9	\$7	100 \$5	300
Warehouse requirement	300	200	200	700

$$\begin{aligned}
 \text{Total Cost} &= \$5(100) + \$4(200) + \$3(100) + \$9(200) + \$5(100) \\
 &= \$3,900
 \end{aligned}$$

EXERCISE

9-16 (1)

Perusahaan kayu Saussy Lumber mengapalkan lantai kayu pinus ke tiga gudang suplai dari pabrik-pabriknya yang terletak di Pineville, Oak Ridge, dan Mapletown. Tentukan jadwal pengiriman terbaik untuk data yang tabel yang diberikan. Gunakan northwest corner rule dan the stepping-stone method.

9-16 (2)

To From	Supply House 1	Supply House 2	Supply House 3	Mill Capacity (Tons)
Pineville	\$3	\$3	\$2	25
Oak Ridge	4	2	3	40
Mapletown	3	2	3	30
Supply House Demand (Tons)	30	30	35	95

9-17 (1)

Perusahaan kereta api Krampf Lines memiliki spesialisasi dalam pengiriman batu bara. Pada hari Jumat, 13 April, Krampf memiliki sejumlah gerbong kosong di beberapa kota berikut ini:

TOWN	SUPPLY OF CARS
Morgantown	35
Youngstown	60
Pittsburgh	25

9-17 (2)

Pada hari Senin, 16 April, beberapa kota lainnya akan memerlukan sejumlah gerbong sebagai berikut:

TOWN	DEMAND FOR CARS
Coal Valley	30
Coaltown	45
Coal Junction	25
Coalsburg	20

9-17 (3)

Dengan menggunakan bagan jalur rel kereta api dari kota ke kota, bagian pengiriman membangun tabel jarak untuk masing-masing kota. Hasilnya dapat dilihat pada tabel berikut. Minimisasi total jarak untuk memindahkan gerbong ke lokasi baru dan tentukan pengiriman gerbong terbaik.

FROM \ TO	COAL VALLEY	COALTOWN	COAL JUNCTION	COALSBURG
MORGANTOWN	50	30	60	70
YOUNGSTOWN	20	80	10	90
PITTSBURGH	100	40	80	30

THANK YOU